

SECURE® 120 ALARM

WITH NURSE CALL INTERFACE & HOLDER

INCLUDES TAMPER-PROOF "IN-ROOM SOUND" SWITCH TO SILENCE ALARM IN RESIDENT'S ROOM

Can be used with Secure® Bed Pads (Bed Pad-1 or Bed Pad-3), Chair Pad (Chair PADS-1), Under Mattress Pad (SUMP-1), Toilet Pad (STP-1) & Seat Belt (SB-1)

Model # SUA-120 • Made in China

The Secure® 120 Alarm is a tamper-resistant alarm created for nursing homes and hospitals that require an alarm sound decibel level up to 120 decibels. This alarm is ideal for care facilities with resident rooms toward the end of long hallways. In addition, the option of setting the decibel level at 120, 90 or 80 decibels enables staff to determine an appropriate sound level for several different room locations.

The feature rich Secure® 120 Alarm was designed to provide the option of in room silence while providing maximum fall management benefits. The alarm is to be used with Secure® Bed or Chair Sensor Pads or the Secure® Seat Belt, Secure® Toilet Pad or Secure® Under Mattress Pad as part of a total fall management program. If using with the Secure® Seat Belt please refer to your seat belt instructions. The following instructions cover the use of this product with Secure® Bed or Chair Sensor Pads.

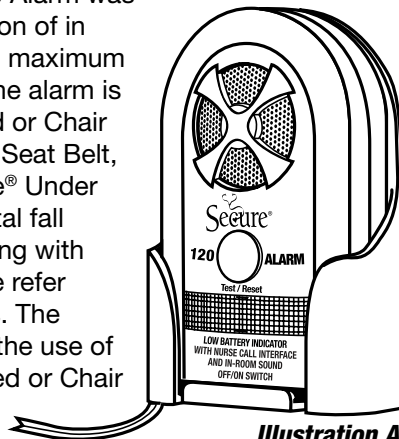

Illustration A

This product is not a restraint.

It will not prevent a resident from getting out of their bed or chair.

INSTRUCTIONS

- Please refer to Illustration B for the following steps:
 - Open the sliding tamper resistant cover on side of alarm with Phillips screw driver (included).
 - If using a nurse call cable determine if you want to silence the alarm in the resident's room. If you **DO NOT** want the alarm to sound in the resident's room when using the nurse call feature, slide "Off/On" switch to the "Off" position. If you **DO** want the alarm to sound in the room and at the nurse's station slide the "Off/On" switch to the "On" position.

PLEASE NOTE: IF YOU DECIDE TO SILENCE THE ALARM IN THE RESIDENT'S ROOM WHEN USING THE NURSE CALL SYSTEM THE "OFF/ON" SWITCH SHOULD BE IN THE "OFF" POSITION. IF YOU WANT THE ALARM TO SOUND IN THE RESIDENT'S ROOM THE NEXT TIME USED YOU MUST MOVE THE "OFF/ON" SWITCH TO THE "ON" POSITION.

- Insert nurse call plug into opening marked "Nurse Call." Insert pin of bed or chair sensor pad into opening marked "Sensor Pad."

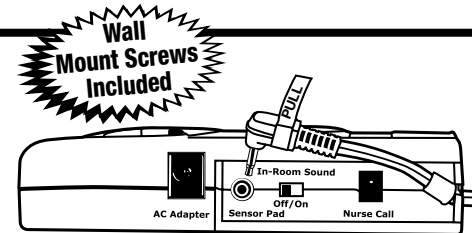

Illustration B

CAUTION! ALWAYS remove sensor pad pin from alarm by pulling straight up on the white "PULL" tab. DO NOT attempt to remove pin any other way or you may damage pin and void warranty.

- Carefully thread the nurse call cord and/or pad cord through the slot opening at the bottom of the alarm.
- Close sliding tamper-resistant cover and tighten screw with Phillips screwdriver to prevent tampering.

- Please refer to Illustration C for the following steps:

- Open battery cover on back of alarm by removing tamper-resistant screw and sliding the battery cover in the direction of the arrow with your thumbs. The battery cover will open and stay attached to the alarm. Install three "AAA" batteries "included" into battery compartment per the "+/—" diagrams on the bottom of the battery holder. The alarm will beep twice.
- The alarm also has an AC/DC Adapter plug-in option on the side of the alarm. Please refer to Illustration B. If at all possible it is recommended that you use an AC/DC Adapter along with the batteries to prolong the life of the batteries. (It is recommended that you use our Secure® 6-Volt AC/DC Adapter to avoid possible damage to the alarm. See our order form to order our Secure® 6-Volt AC/DC Adapter - Model # ACDC-1.)

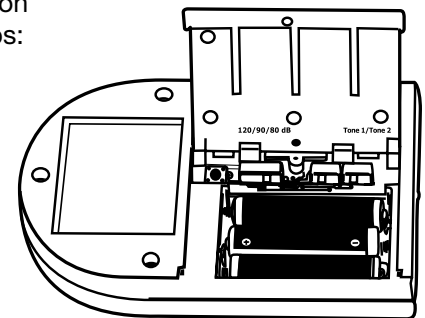

Illustration C

Continued

Please see our complete line of Secure® fall & wandering prevention products at www.padalarm.com.

Highest Quality...Lowest Prices...Guaranteed!

Personal Safety Corporation • Cedar Rapids, Iowa 52402 • 800.3.SECURE

SECURE[®] 120 ALARM WITH NURSE CALL INTERFACE & HOLDER

Continued

3. You will need to choose the decibel level that best suits your situation. You can test each decibel level by moving the “120/90/80 dB” switch to each decibel level and pressing and holding the “Test/Reset” button on the front of the alarm. Once your selection is made replace the battery cover and tighten tamper-resistant screw.
4. **PLEASE NOTE:** If using the Secure[®] Bed Pad (Bed Pad-1 or Bed Pad-3), Secure[®] Chair Pad (Chair Pad-1), Secure[®] Toilet Seat Pad (STP-1), Secure[®] Under the Mattress Pad (SUMP-1), Secure[®] Seat Belt (SB-1) see instructions printed on pad or included with seat belt.
CAUTION! ALWAYS remove sensor pad pin from alarm by pulling straight up on the white “PULL” tab. DO NOT attempt to remove pin any other way or you may damage pin and void warranty.
5. You have now completed all the alarm function set up steps.
6. Remove the paper covering from the top of the Velcro[®] piece attached to the bottom of the alarm. Slide the alarm into the alarm holder carefully threading the pad cord through the slot opening at the bottom of the holder. Press down on the top of the alarm while pulling the cords through the opening to secure the Velcro[®] piece to the bottom of the holder. The alarm is now firmly in the holder. Please refer to Illustration A. When it is necessary to remove the alarm from the holder simply pull up on the alarm to separate the Velcro[®] pieces. Remove the wires by sliding them through the slot at bottom of alarm holder to completely remove the alarm from the holder.
7. Affix the alarm and holder securely to the side of the bed or chair out of sight and reach of the resident. Simply wrap the Velcro[®] strap with the rubberized non-slip backing attached to the back of the holder tightly around railing or frame of bed or wheelchair. Holder placement should be easily accessible to staff. Secure excess pad cord to avoid damaging the cord.
8. Carefully assist resident onto pad or into seatbelt as explained on pad or instruction sheets.
9. Once the resident is positioned in the center of the pad the alarm will beep twice to indicate that the alarm is functioning properly. The alarm will allow for normal movement. **However, if the resident gets off sensor pad the alarm will sound to alert staff. When the resident gets back on the pad the alarm will automatically reset.**
10. When staff removes resident from pad for whatever reason the alarm will sound. **Note: As a tamper resistant feature please firmly press the “Test/Reset” button 3 times to stop alarm sound.**
11. When the resident is positioned back on the pad the alarm will beep twice signaling that the alarm has automatically reset.
12. **The alarm and sensor pad should be checked prior to each use for proper functioning. Please note: The system can be checked while resident is on the pad by simply pressing “Test/Reset” button. The alarm will beep twice. DO NOT ASSUME! TEST EACH TIME THE SYSTEM IS USED.**
13. The light bar on the front of the alarm also functions as a low battery indicator. When the batteries are low and require changing the light bar will flash blue intermittently and the alarm will emit a beeping sound. **Note: As a safeguard simply pressing the reset button will not stop the alarm from beeping when the batteries are low. The blue light will continue to flash and the beeping sound will continue until the batteries are changed.**

12 MONTH LIMITED WARRANTY

Personal Safety Corporation warrants this product to be free from factory defects in materials and workmanship for a period of 12 months from the date of purchase. Void if this product has been misused, abused or punctured. No warranty of responsibility of use expressed or implied.

CAUTION!

This product is not a restraint. It will not prevent a resident from getting out of their bed or chair. This product is designed as a monitor, alerting the staff when the resident has risen from their bed or chair. This product is to be used in conjunction with a total fall prevention program.

Please see our complete line of Secure[®] fall & wandering prevention products at www.padalarm.com.

Highest Quality...Lowest Prices...Guaranteed!

Personal Safety Corporation • Cedar Rapids, Iowa 52402 • 800.3.SECURE