

Under Seat Alarm w/ Holder

Alarm to be used ONLY with the Under Seat Adjustable Switch Bar (USAB-1)

Model # USA-1 • Made in China • Patent Pending

WARNING: The Under The Seat Alarm (USA-1) must ONLY be used with the Adjustable Switch Bar (USAB-1). The alarm will not function with any other fall monitoring devices such as bed or chair pads. DO NOT ATTEMPT TO CONNECT ANY OTHER FALL MONITORING DEVICE TO THE UNDER THE SEAT ALARM.

Operating Instructions:

The feature rich Secure[®] Under Seat Alarm was designed to provide maximum fall management benefits. The alarm is to be used **ONLY** with the Secure[®] Under Seat Adjustable Switch Bar as part of a total fall management program. **This product is not a restraint. It will not prevent a resident from getting out of their chair.**

1. Please refer to Illustration A below for the following steps:

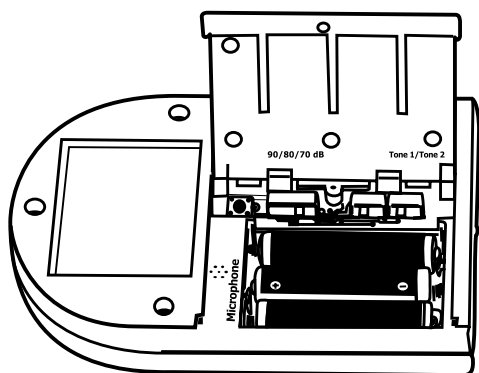

Illustration A

- Open battery cover on back of alarm by removing tamper-proof screw with phillips screwdriver included and sliding the battery cover in the direction on the arrow with your thumbs. The battery cover will open and stay attached to the alarm. Install three "AAA batteries included" into battery compartment per the "+/-" diagrams on the bottom of the battery holder. The alarm will beep twice and stop.
- The alarm also has an AC adapter plug-in option on the side of the alarm. Please refer to Illustration B. If at all possible it is recommended that you use an AC/DC Adapter along with the batteries to prolong the life of the batteries. (See our order form to order our Secure[®] 6-Volt AC/DC Adapter – Model # ACDC-1).
- The alarm features two different alarm tones for roommate or sound preference options. Decide if you would like a continuous alarm tone or a pulsating alarm tone. If you would like a continuous alarm tone move the "Tone 1/Tone 2" switch to the left so that the switch is positioned under the "Tone 1. To hear this tone, simply press and hold down the "Test/Reset" button on the front on the alarm.
- If you would like to have a pulsating alarm tone move the "Tone 1/Tone 2" switch to the right so that it is positioned under "Tone 2". To hear this sound simply

press and hold down the "Test/Reset" button on the front of the alarm.

- Once you are comfortable with your alarm tone selection you will need to choose the decibel level by moving the "90/80/70 dB" switch to each decibel level and pressing and holding the "Test/Reset" button on the front of the alarm.
 - You have now completed all the alarm function set up steps. Close the battery cover and replace the tamper-proof screw.
2. Please refer to Illustration B below for the following steps:

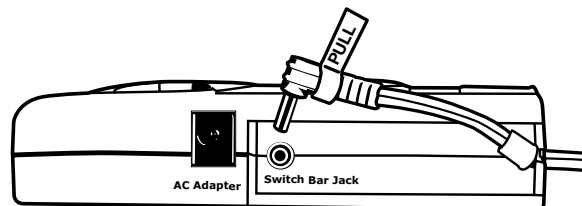

Illustration B

- Remove tamper-proof screw from sliding cover on side of alarm. Slide cover in the direction of the arrow on cover. Fully insert metal pin of Under The Seat Adjustable Switch Bar connecting wire into opening marked "Switch Bar Jack." Push connecting wire down into slot opening at the end of alarm making certain the plastic piece attached to wire is on the inside of the alarm opening. Replace the sliding cover and attach to alarm with tamper proof screw.

CAUTION! ALWAYS remove switch bar pin from alarm by pulling straight up on the white "PULL" tab. DO NOT attempt to remove pin any other way or you may damage pin and void warranty.

- Remove the paper covering from the top of the Velcro[®] piece attached to the bottom of the alarm. Slide the alarm into the alarm holder carefully threading the switch bar cord through the slot opening at the bottom of the holder. Press down on the top of the alarm while pulling the cord through the opening to secure the Velcro[®] piece to the bottom of the holder. When it is necessary to remove the alarm from the holder simply pull up on the alarm to separate the Velcro[®] pieces. Remove the wires by sliding them through the slot at bottom of alarm holder to completely remove the alarm from the holder.

- c. Affix the alarm and holder securely to back of wheelchair out of sight and reach of resident. Simply wrap the Velcro® strap with the rubberized non-slip backing attached to the back of the holder tightly around wheelchair frame. Holder placement should be easily accessible to staff. Secure excess cord to avoid damaging cord.
- d. See Under Seat Adjustable Switch Bar instruction sheet for bar set up.
- e. To test system press either the “Test/Reset” button on the front of the alarm or apply pressure on the seat of the wheelchair after installing the Under Seat Adjustable Switch Bar. To stop alarm from sounding simply press the “Test/Reset” button on the front of the alarm 3 times quickly in 1.5 seconds.
- f. Carefully assist resident into wheelchair. If using a seat cushion there should not be any resident discomfort when seated. If the resident is sitting directly on the seat, the top of the switch bar may cause discomfort to resident’s buttocks depending on the resident’s weight. The discomfort can be eliminated by either a seat cushion or lowering the switch bar as directed in instruction sheet included with the Under Seat Adjustable Switch Bar.
- g. The alarm will allow for normal movement. However, if resident attempts to exit the wheelchair the alarm will sound to alert staff. When resident sits back down the alarm will stop sounding and automatically reset.
- h. However, the light bar will continue to flash red intermittently to let staff members know which resident activated the alarm. The staff member needs to firmly press the “Test/Reset” button 3 times quickly in 1.5 seconds to stop flashing light. The alarm is then automatically reset.
- i. When staff removes resident from wheelchair for whatever reason the alarm will sound. To silence the alarm simply press the “Test/Reset” button on front of alarm. **NOTE: As a tamper resistant feature please press the “Test/Reset” button 3 times quickly in 1.5 seconds to stop alarm from sounding.**
- j. When the resident is positioned back in the wheelchair the alarm will beep twice signaling that the alarm has automatically reset.
- k. The alarm and switch bar should be checked prior to each use for proper functioning. Please note: The system can be checked while resident is on the switch bar by simply pressing “Test/Reset” button. The alarm will beep to indicate proper alarm functioning. **DO NOT ASSUME! TEST EACH TIME THE SYSTEM IS USED!**
- l. The light bar on the front of the alarm also functions as a low battery indicator. When the batteries are low and require changing the light bar will flash blue intermittently and the alarm will emit a beeping sound. **Note: As a safeguard simply pressing the reset button will not stop the alarm from beeping when the batteries are low. The blue light will continue to flash and the beeping sound will continue until the batteries are changed.**

Please note: For resident safety, the Under Seat Alarm does not have an “On/Off” switch. Staff members do not have to remember to turn alarm back on as alarm has an auto reset feature.

12 MONTH LIMITED WARRANTY

Personal Safety Corporation warrants this product to be free from factory defects in materials and workmanship for a period of 12 months from the date of purchase. Void if this product has been misused, abused or punctured. No warranty of responsibility of use expressed or implied.

WARNING!

Must remove switch bar and alarm before cleaning wheelchair or using wheelchair when showering resident. Failure to do so will damage system and will void warranty.

Please see our complete line of Secure® fall & wandering prevention products at www.padalarm.com



Secure® Hip Protectors - SHP
(In five sizes)

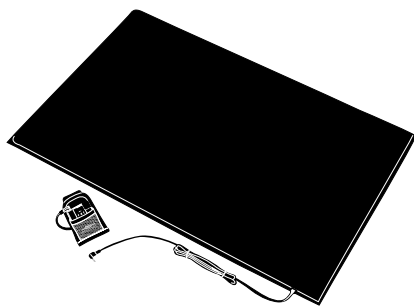

Secure® Reversible Safety Floor Mat - MAT-1 & MAT-2

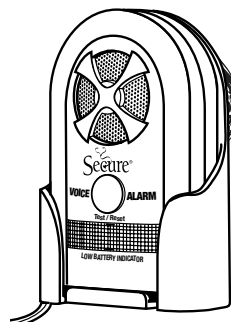

Secure® Voice Alarm SVA-1



Secure® Universal Alarm SUA-1

Highest Quality...Lowest Prices...Guaranteed!

Personal Safety Corporation • Cedar Rapids, Iowa 52402 • 800.3.SECURE